

URBAN
Bonfire[™]
URBAIN

PLANTERS
CATALOG 2020



3700 Saint-Patrick #110
Montréal, Qc. H4E 1A2
design@urbanbonfire.com | +1 (866) 898-5354
urbanbonfire.com

TECHNICAL DETAILS

CUBE, PARTITION & TROUGH PLANTERS

Fully welded thick grade aluminum, powder coated and built to last. Each Cube, Partition and Trough Planter comes equipped with pre machined drainage holes and 1 ½" geotextile covered insulation.

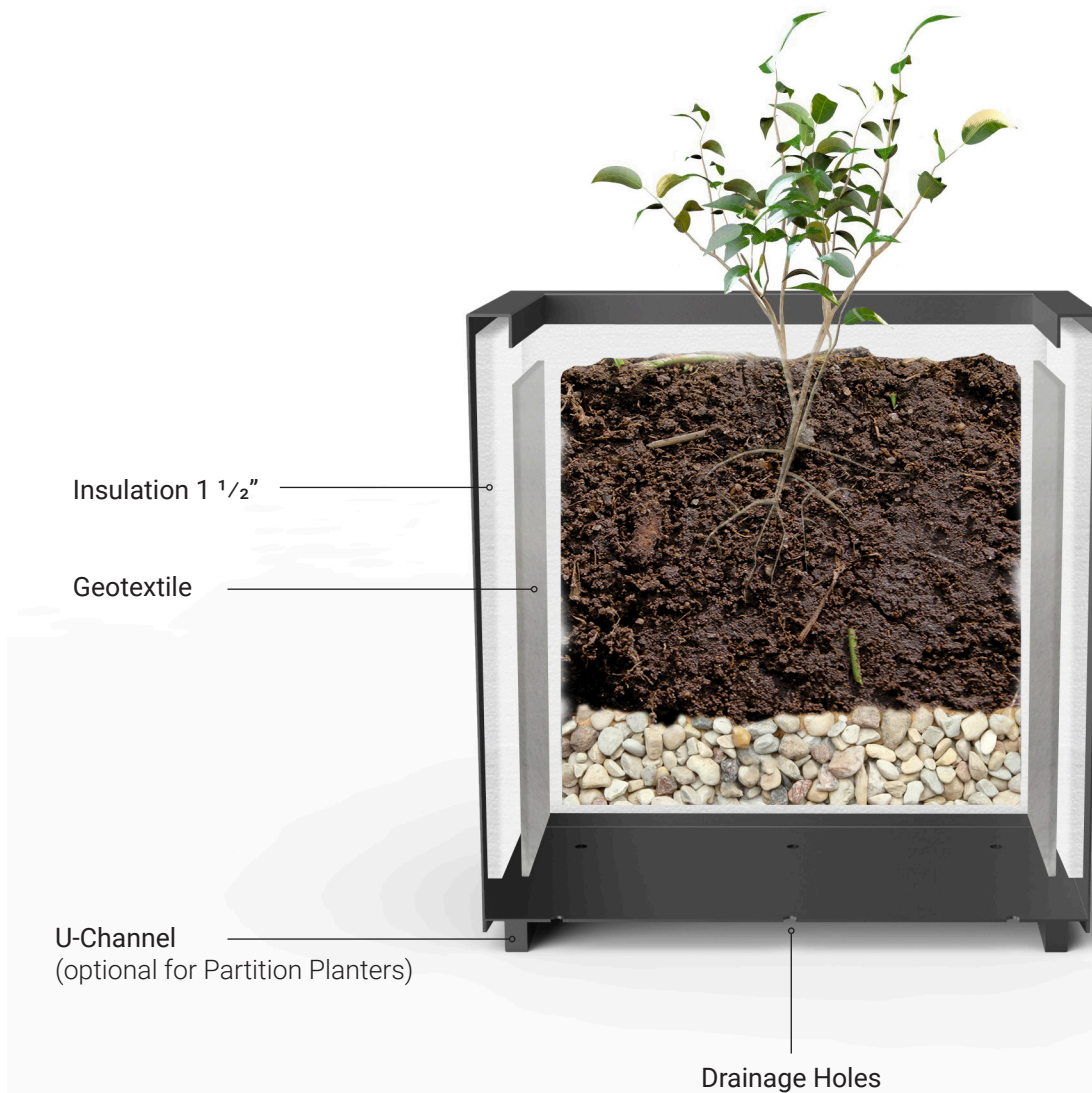

TECHNICAL DETAILS

COUNTERTOP PLANTERS

Fully welded thick grade aluminum, powder coated and built to last. The drainage holes at the bottom ensure a proper drainage and prevent over watering. Our series of Countertop Planters is designed for a minimal and sleek look, perfect for planting herbs or other annuals.



Spacer

Drainage Holes



Ensuring Proper Drainage

When installing your Urban Bonfire outdoor kitchen, give an angle so the back of the kitchen leans down slightly to the ground. This will help proper drainage to your Countertop Planter.



3700 Saint-Patrick #110
Montréal, Qc. H4E 1A2
design@urbanbonfire.com | +1 (866) 898-5354
urbanbonfire.com

POWDER COATING FINISHES

Our custom formulated “Super Durable” finishes add depth to the colors and resistance to fingerprints and stains.



Onyx

A deep, dark black that is sure to create a standout piece in any environment.



Anthracite

Modern dark gray with slate undertones. Elevates contemporary and outdoor urban environments.



Artesan

A dark gray finish with a warm bronze undertone. Designed to accent wood and natural limestone while still creating a welcome contrast through its depth of tone.

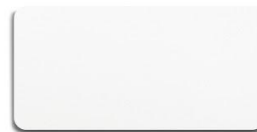

Chantilly

This crisp white works in almost any outdoor setting. Reflecting tones of silk and clean linen.

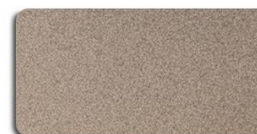

Clay

An elegant and versatile rich beige. Enhances the mood and atmosphere of any classic outdoor living space.

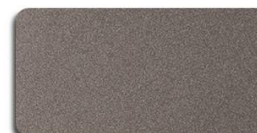

Pewter

Warm dark gray with bronze undertones. Adds a refined touch to any outdoor environment.

COUNTERTOP PLANTER



COUNTERTOP PLANTER

Designed for small herb gardens or annuals, this planter sits directly on the countertop. It is fully welded and made of thick marine grade aluminum. Includes choice of powder coating in any one of our standard colors.

A-PLANTER-COUNTER-18x6x8

Dimension: L18" x W6" x H8"



Powder coating in Artisan

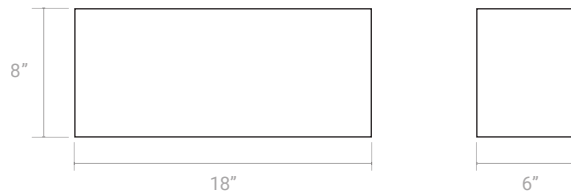
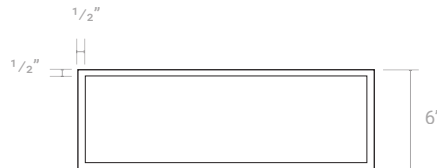

A-PLANTER-COUNTER-24x6x8

Dimension: L24" x W6" x H8"



Powder coating in Onyx

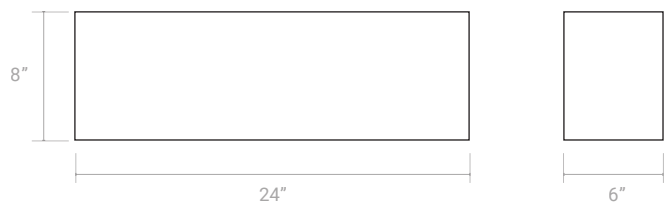
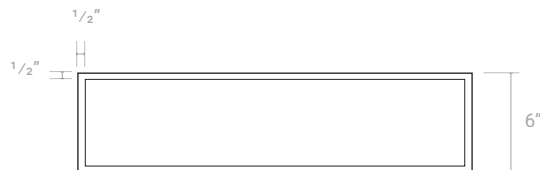

A-PLANTER-COUNTER-30x6x8

Dimension: L30" x W6" x H8"



Powder coating in Anthracite

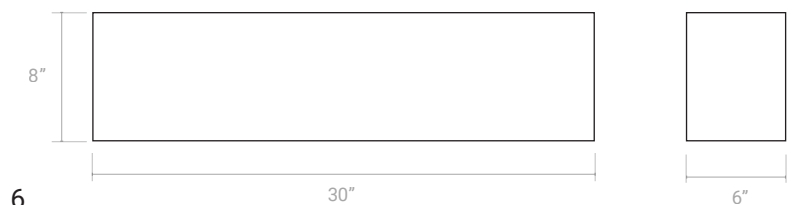
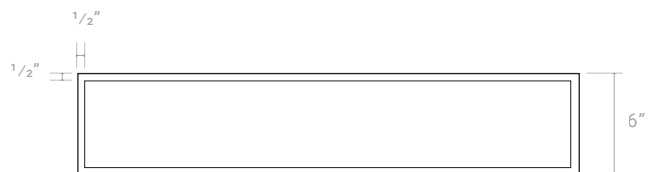

CUBE PLANTER



CUBE PLANTER

Designed to fill a space without adding extra storage, a Cube Planter could be a great addition to your outdoor kitchen. These are freestanding, fully welded and made of thick marine grade aluminum. Includes choice of powder coating in any one of our standard colors.

A-PLANTER-CUBE-18x18x18

Dimension: L18" x W18" x H18"

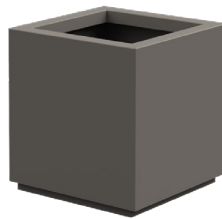

Powder coating in Artisan

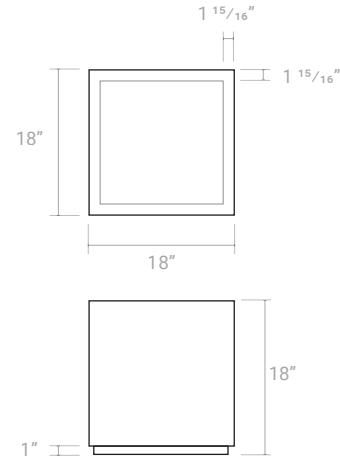

A-PLANTER-CUBE-21x21x21

Dimension: L21" x W21" x H21"

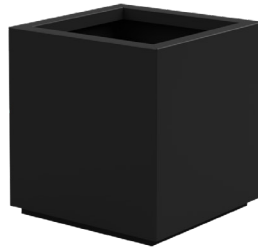

Powder coating in Onyx

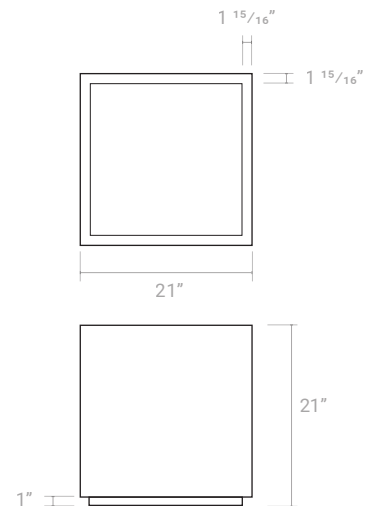

A-PLANTER-CUBE-24x24x24

Dimension: L24" x W24" x H24"

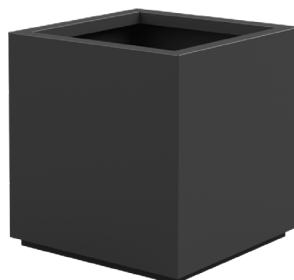

Powder coating in Anthracite

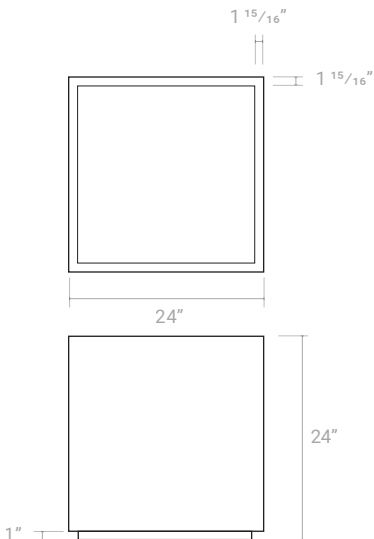

CUBE PLANTER

Designed to fill a space without adding extra storage, a Cube Planter could be a great addition to your outdoor kitchen. These are freestanding, fully welded and made of thick marine grade aluminum. Includes choice of powder coating in any one of our standard colors.

A-PLANTER-CUBE-28x28x28

Dimension: L28" x W28" x H28"

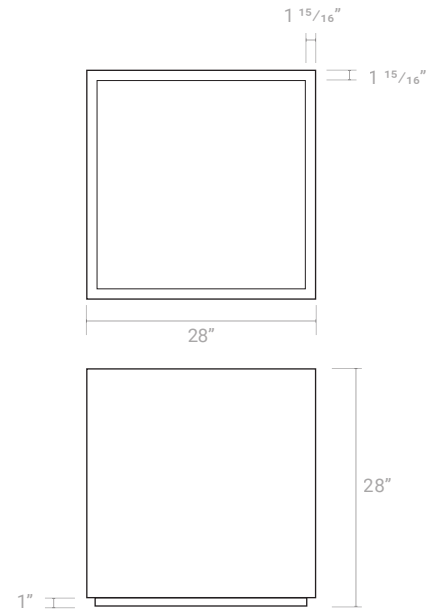
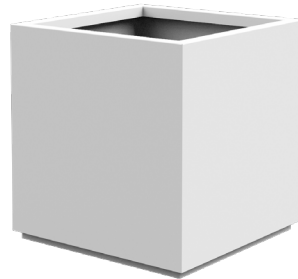

Powder coating in Chantilly

A-PLANTER-CUBE-36x36x36

Dimension: L36" x W36" x H36"

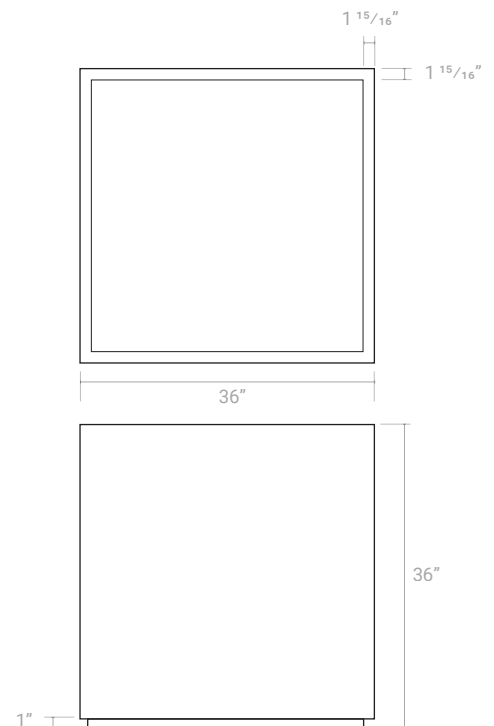

Powder coating in Artesan

PARTITION PLANTER





URBAIN

3700 Saint-Patrick #110
Montréal, Qc. H4E 1A2
design@urbanbonfire.com | +1 (866) 898-5354
urbanbonfire.com



Our Partition Planters offer the option of having an indented u-channel base to give a subtle elevation. Ideal for a free standing planter look in any environment.

The option to sit directly on the ground (as below) is also available and is a perfect way to create a seamless backdrop for your Urban Bonfire kitchen.



PARTITION PLANTER

Designed to back up against a kitchen to create a free standing backsplash structure, our Partition Planters are also ideal for delineating a space and creating more intimate environments.

A-PLANTER-PARTITION-36x10x42

Elevated look with our indented u-channel base.

Dimension: L36" x W10" x H42"



Powder coating in Pewter

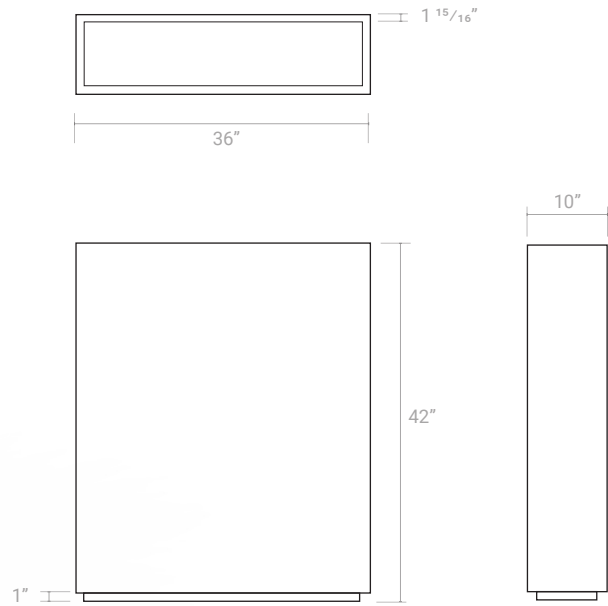

A-PLANTER-PARTITION-36x10x42-NC

Dimension: L36" x W10" x H42"



Powder coating in Clay

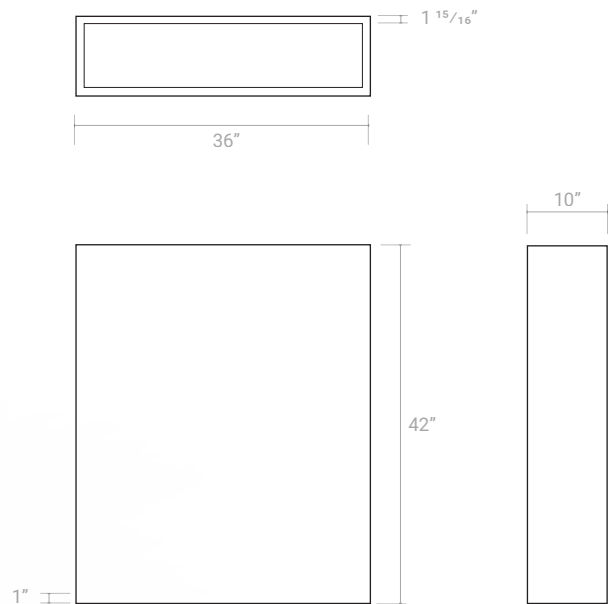

PARTITION PLANTER

Designed to back up against a kitchen to create a free standing backsplash structure, our Partition Planters are also ideal for delineating a space and creating more intimate environments.

A-PLANTER-PARTITION-42x12x42

Elevated look with our indented u-channel base.

Dimension: L42" x W12" x H42"



Powder coating in Artisan

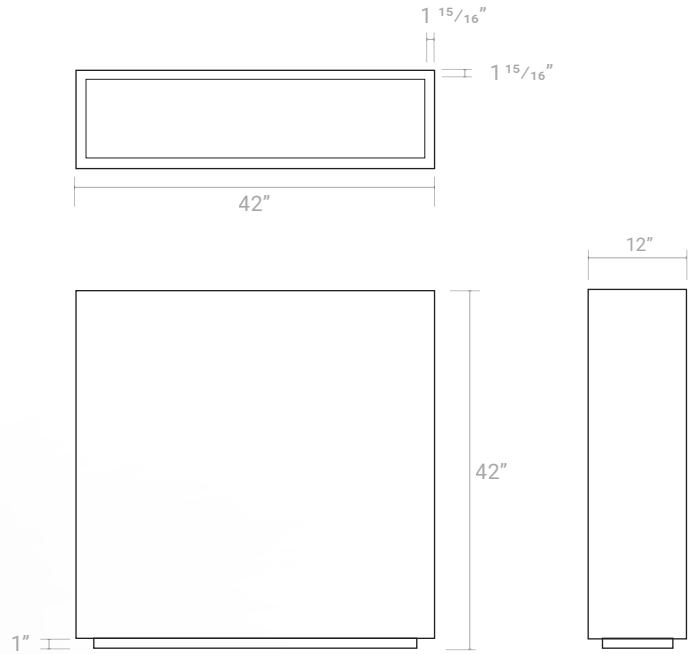

A-PLANTER-PARTITION-42x12x42-NC

Dimension: L42" x W12" x H42"



Powder coating in Anthracite

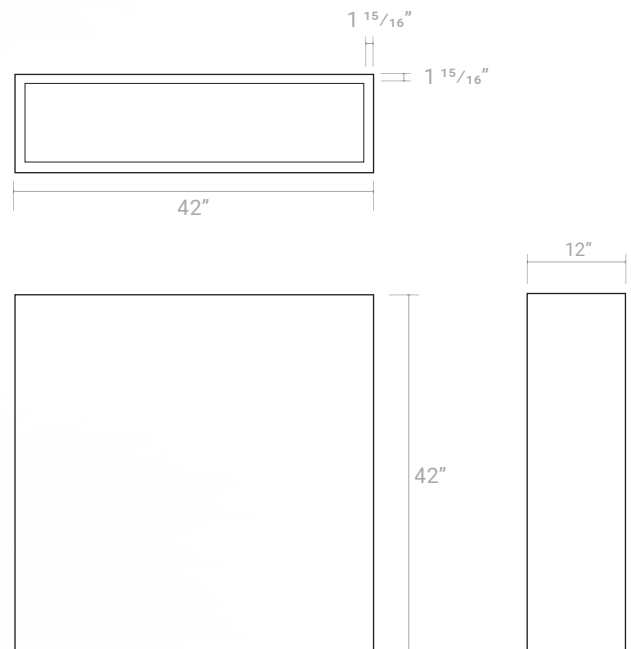

TROUGH PLANTER



TROUGH PLANTER

Designed for lower gardening plots, or for creating a bench, a trough planter is a great way to add an accessible garden to your outdoor space. These are freestanding, fully welded and made of thick marine grade aluminum. Includes choice of powder coating in any one of our standard colors.

A-PLANTER-TROUGH-36x24x7

Dimension: L36" x W24" x H7"



Powder coating in Onyx

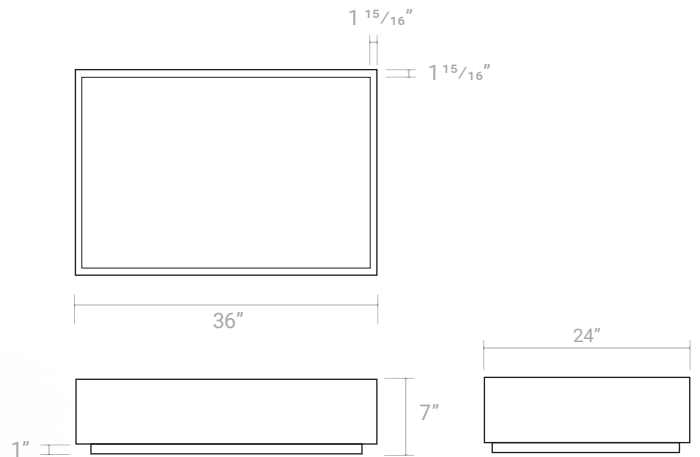

A-PLANTER-TROUGH-48x18x10

Dimension: L48" x W18" x H10"



Powder coating in Anthracite

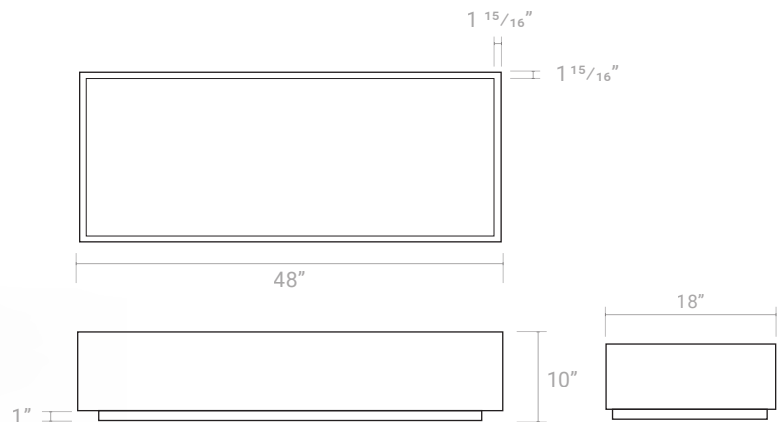

A-PLANTER-TROUGH-48x24x9

Dimension: L48" x W24" x H9"



Powder coating in Artesan

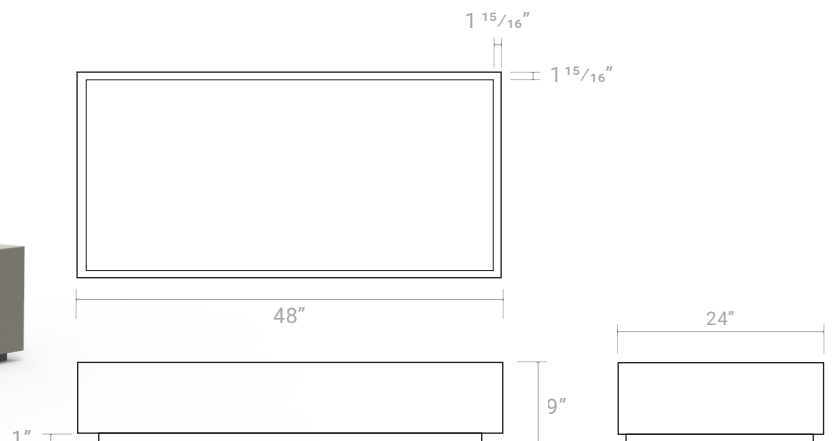

TROUGH PLANTER

Designed for lower gardening plots, or for creating a bench, a trough planter is a great way to add an accessible garden to your outdoor space. These are freestanding, fully welded and made of thick marine grade aluminum. Includes choice of powder coating in any one of our standard colors.

A-PLANTER-TROUGH-48x24x20

Dimension: L48" x W24" x H20"

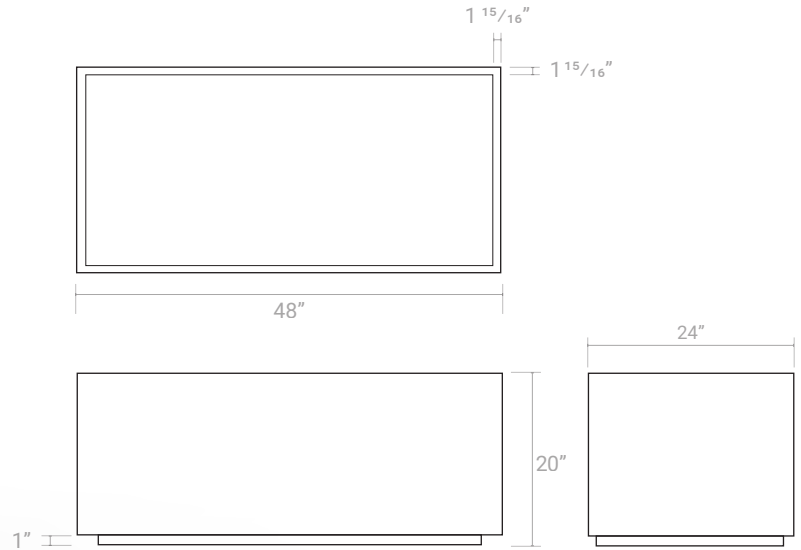

Powder coating in Chantilly

A-PLANTER-WOODBENCH-24x24

Bench accessory made of IPE hardwood slats for A-PLANTER-TROUGH-48x24x20. Also available as a full bench (2x IPE Wooden Bench Insert).

Dimension: L24" x W24"



Powder coating in Chantilly